

Iskra TELA-SEM
Precision in measuring

TGM-170

MOUNTING INSTRUCTIONS

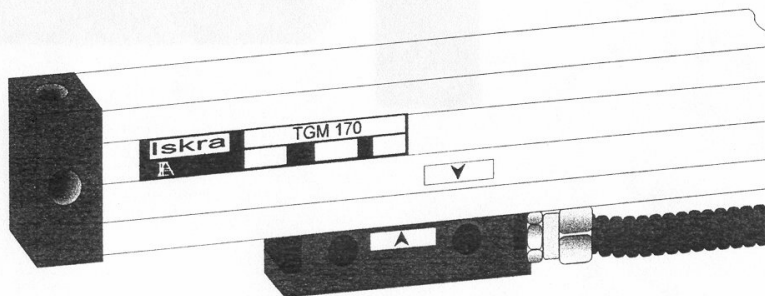

ID = 430 211 980 000
edition 3, 5/98

1. CAUTION

Measuring transducer operates on the photoelectric sensing principle and is very sensitive to dirt, shocks and bending. It should be treated carefully, in order to prevent permanent damage of the glass scale in the housing.

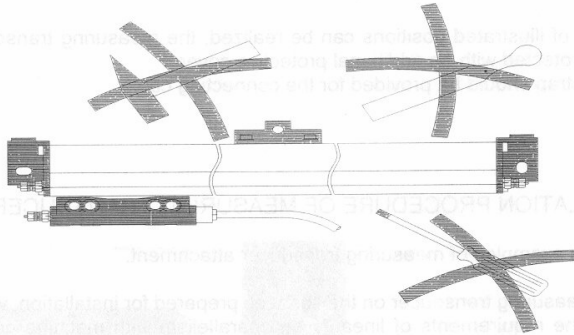

2. GENERAL DESCRIPTION

Reliable operation and accuracy of the measuring transducer TGM 170 is guaranteed only when it is installed on the machine strictly according to instructions.

It is very important to choose the right place for attachment. The best way for the system to be installed is as close as possible to the guides on the machine or on the carriage, respectively. Take care, that certain measuring system parts do not surpass machine dimensions and project into the space reserved for other purposes.

Two mounting surfaces are required for installation of the measuring transducer. One of these surfaces should be situated on the fixed and the other on the moving part of the machine. Both surfaces have to be linear and mutually parallel along the entire movement length (see the requirements regarding linearity and tolerances in the drawing). Possible non-linearities of mounting surfaces and their non-parallelism with the guides reduce measuring transducer accuracy.

If possible, the measuring scale should be mounted on the moving part of the machine, because these enables fixed installation of slider cable. If the machine does not offer any appropriate mounting surfaces, they can be obtained by means of additional attached elements.

3. CHOICE OF MEASURING TRANSDUCERS POSITION

Measuring transducer is protected against water jets, except on the side of lock washers. In order to prevent intrusion of dust, scrapings and liquids into the case, the measuring transducer should be installed in such a position that the side with lock washers is protected against direct spattering of water and dirt. Fig. 1 shows examples of required positions.

When none of illustrated positions can be realized, the measuring transducer should be protected with an additional protective cover.
A straining strap should be provided for the connecting cable.

4. INSTALLATION PROCEDURE OF MEASURING TRANSDUCER

Fig. 2 shows examples of measuring transducer attachment.

Place the measuring transducer on the surfaces prepared for installation, which must fulfill the requirements of linearity and parallelism with machine guides (fig. 3, 4 gives the measures and tolerances). Adjust the measuring scale so as to achieve required parallelism with machine guides and refasten it.

Move the reading head closer, align it parallelly with machine guides, assure specified distance from the scale and fasten it (take in consideration max. screw tightening torque).

Move machine carriage in both directions, take care that the right or left extreme position does not surpass the measuring transducer level. Check the distance between the measuring scale and reading head, which has to be 1.0 ± 0.3 mm along the entire measuring length.

5. SYSTEM FUNCTION TESTING

Connect the measuring transducer to the measuring readout, taking care that the readout is not under mains voltage.

Connect the measuring readout to mains voltage and check whether the measuring transducer is operating.

Move the carriage to one of its extreme positions. Set the zero point on the dial gauge and zero the measuring transducer. Now move the carriage away from the dial gauge along the entire travel and return to the zero point. The zero point of the dial gauge and the zero point of the readout should be synchronized.

After correct installation and checking, it is recommended to protect fastening screws against loosening, by using a glue, which permits disassembly.

6. MAINTENANCE OF THE MEASURING TRANSDUCER

Measuring transducer is provided with a rubber gasket which closes access to dirt. The gasket is resistant to mineral oils, petrol, alkali and water. In order to minimize wear and conserve flexibility and, thereby, the sealing quality it is recommended to lubricate sliding surfaces of the gasket with a silicone grease, approximately every 40 000 slider movements (800 working hours). Take care not to apply too much grease because it could get inside the transducer.

No other maintenance of the measuring transducer is required. If the transducer does not operate or operates incorrectly, call an authorized service.

7. ACCURACY

Each measuring transducer is carefully tested at temperature $20^{\circ}\text{C} \pm 0.1^{\circ}\text{C}$, is provided with its measuring report and guarantees high accuracy when correctly installed.

CAUTION: Incorrect installation, change of temperature, wear and play in machine guides, as well as drooped guides (carriage) greatly reduce accuracy.

Avoid great short-time temperature changes, because the larger machine mass expands and contracts more slowly than the smaller mass of measuring transducer, and increases error.

Precise operation of the measuring transducer also requires maintenance of the machine tool according to instructions of the manufacturer. Guides should be adjusted and certain machine parts lubricated at regular time intervals. Individual measurement on the table and machine should be carried out with blocked guides. When the measuring readout indicates a difference between the states at blocked and unblocked guides, readjust machine guides.

Determination of measuring error along the entire measuring length, caused by incorrect installation of the machine fault, is a complicated operation, and should be carried out by an expert.

MECHANICAL DATA		
Standard measuring length Lm (mm)	170/220/270/320/370/420/470/520/570/620/ 670/720/770/820/920/1020/1140/1240/1340/ 1440/1540/1640/1740/1840/2040/2240/2440/ 2640/2840/3040	
Reference mark	Standard position in center. Other positions optional at spacing of 10 mm along the measuring length.	
Accuracy class (max. error in any 1m section at 20°C and correct mounting)	± 10 µm, ± 5 µm, ± 3 µm	
Interval	20 µm	
Resolution	0,5 µm, 1 µm, 5 µm (for DI and DS signals)	
Maximal speed	45 m/min continuously, 60 m/min temporarily	
Permissible acceleration	30 m/s ²	
Moving force for scanning unit	≤ 6N	
Degree of mechanical protection	IP 53 (in compliance with mounting instructions)	
Vibrations (50...2000 Hz)	30 m/s ²	
Shocks (11 ms)	100 m/s ²	
Temperature	operating: 0°C to 50°C storage: -20°C to 70°C	
Permissible relative humidity	20% to 70%	
Cable length	standard 3m, extension in order to 20 m (SI output signals), extension in order to 50 m (DI, DS output signals)	
Mass	0,8 kg + 2,2 kg/m measuring length	
ELECTRICAL DATA		
Output signals	Voltage U_n	Current I_n
DS - square wave inverted RS422A standard	5 V ± 5%	≤ 130 mA
DI - square wave inverted	5 V ± 5%	≤ 130 mA
SI - sine-current wave	5 V ± 5%	≤ 70 mA

Square-wave with inverted signals and RS 422A - DI, DS:

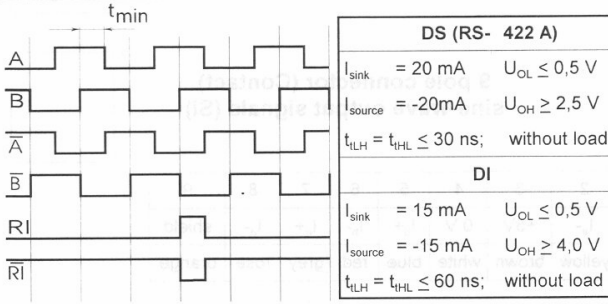

Sinusoidal output signals SI:

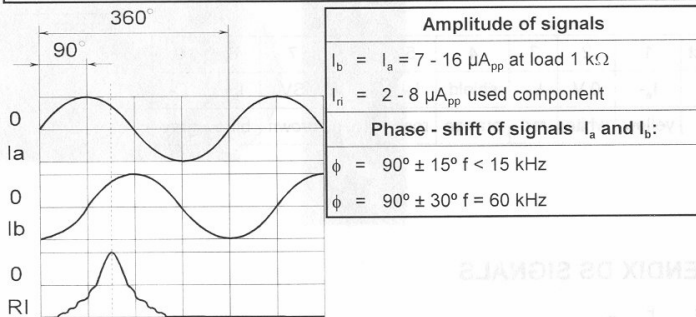

APPENDIX SI SIGNALS

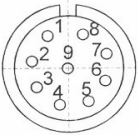
YOU
HAVE

9 pole connector (Contact)
sine-wave output signals (SI)



contact	1	2	3	4	5	6	7	8	9
signal	I_{a+}	I_{a-}	+5V	0 V	I_{b+}	I_{b-}	I_{n+}	I_{n-}	shield
color	green	yellow	brown	white	blue	red	grey	rose	orange

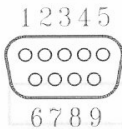

9 pole connector (D-Sub)
sine-wave output signals
(SI)

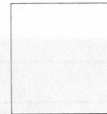

contact	1	2	3	4	5	6	7	8	9
signal	I_{a-}	0 V	I_{b-}	shield	I_{n-}	I_{a+}	SV	I_{b+}	I_{n+}
color	yellow	white	red	orange	rose	green	brown	blue	grey

APPENDIX DS SIGNALS

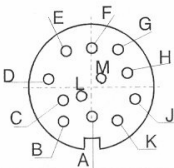

12 pole connector (Amphenol)
square-wave output signals
(DI, DS)

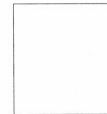

contact	A	B	C	D	E	G	H	K	L
signal	shield	0 V	A	\bar{A}	B	RI	\bar{RI}	+V	\bar{B}
color	orange	white	yellow	green	red	brown	grey	black	pink



**12 pole connector (Contact)
square-wave output signals
(DI, DS)**



contact	1	2	3	4	5	6	7	8	9	10	11	12
signal	\overline{B}	+5V	RI	\overline{RI}	A	\overline{A}	5V	B	shield	0V	0V	+5V
color	green	blue	brown	grey	red	pink	-	yell.	oran.	white		

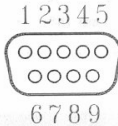

**9 pole connector (D-Sub)
square-wave output signals
(DI, DS)**



contact	1	2	3	4	5	6	7	8	9
signal	shield	\overline{RI}	\overline{B}	\overline{A}	+5V	RI	B	A	0V
color	orange	grey	green	pink	blue	brown	yellow	red	white

APPENDIX SV SIGNALS

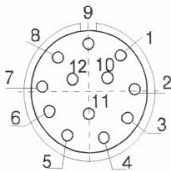

**12 pole connector (Contact)
sine-wave voltage 1Vpp
signals (SV)**



cont.	1	2	3	4	5	6	7	8	9	10	11	12
signal	U_{B-}	+5V	U_{RI+}	U_{RI-}	U_{A+}	U_{A-}		U_{B+}	shield	0V	0V	+5V
color	pink	blue	red	yell.	brown	green	-	gray	oran.	white	white	blue

SPEED AND SCANNING UNIT

Maximum operating speed diagram.

The maximum measuring speed allowed by the mechanical construction is given in the mechanical data table.

The dependence of minimum time interval between two neighboring fronts of square-wave output signals is given at right.

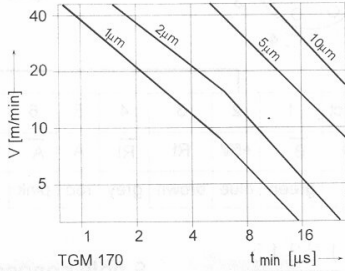

contact	1	2	3	4	5	6	7	8	9	10	11	12
signal	R1	R2	R3	R4	R5	R6	R7	R8	R9	R10	R11	R12
color	orange	grey	green	pink	brown	yellow	red	white	black	blue	grey	white

APPENDIX SV SIGNALS



fig. 1: Dirt contamination side:

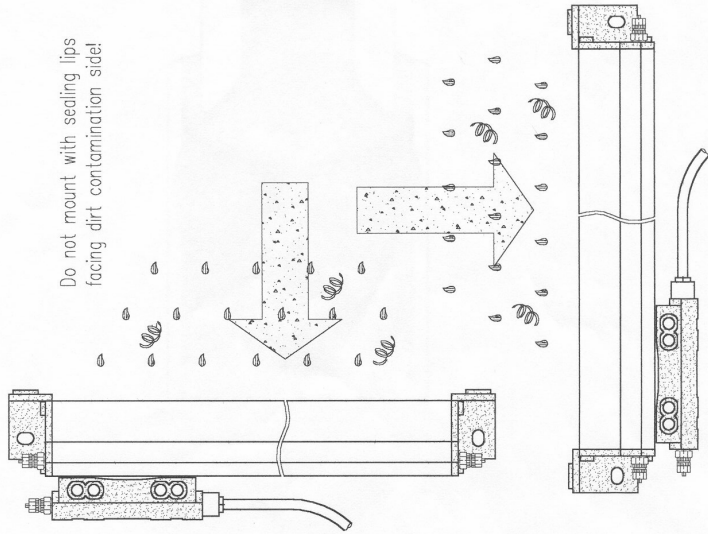

fig. 2: Mounting possibilities:

